



MIS340C12P6H385

Int.Step 12-72VDC, CANopen, AbsE

ServoStep MIS is a series of integrated stepper motors with servo control (closed-loop) and up to 3000 RPM.

It consists of NEMA 17..23..34..43 size motors with holding torques from 0.18 Nm up to 25 Nm. All motors are programmable and have 8 I/O points (each can be DI or DO or AI).

Options include:

- incremental (semi-absolute) encoder*). absolute multiturn encoder
- brake module*)
- radial or axial*) connectors
- CANopen
- Ethernet interface w/built-in switch for easy daisy-chaining and all protocols (Profinet. EtherNet/IP. EtherCAT. Sercos. ModbusTCP/UDP. Powerlink).
- Wireless versions are also possible: WLAN or BlueTooth.
- Special shaft versions include double shaft and hollow shaft. contact JVL to learn which combinations are possible.
- Higher IP versions are also available. *) Depending of other options

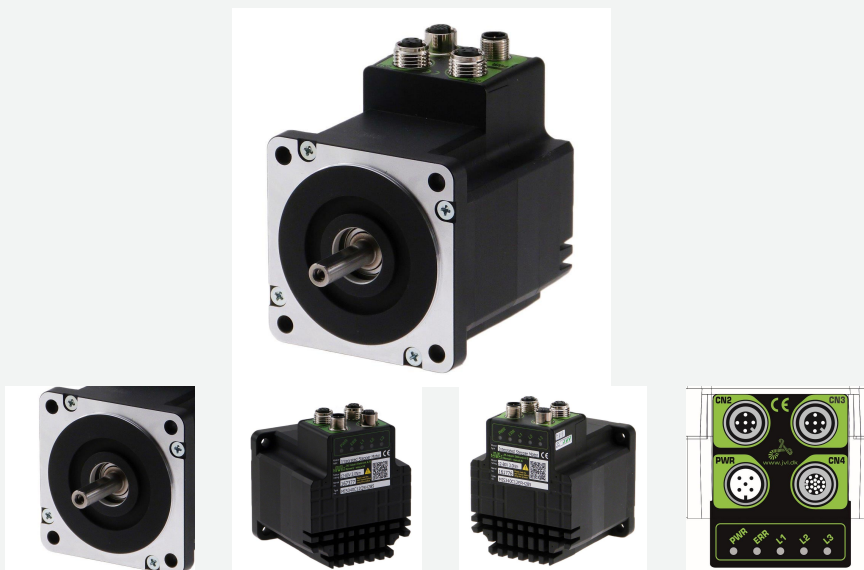

General information

Description	Int.Step 12-72VDC, CANopen, AbsE, 4xM12. 2x5pF:CANopen 17pF:8xDIO/AI +RS422+RS485, High Resolution: 409.600 step/rev. ±0.01 RPM, Programmable (incl. current, position & velocity), Absolute Multiturn Encoder. 1024 CPR ± 5242 Revs, Ø9.53x30.5 mm D-cut, Shaft: IP42, Motor: IP42, 86.4x95 mm Holding Torque: 3.0 Nm Max. 260 W Radial Connector 12-72 VDC Mechanical Power: 260 W		
Manufacture	JVL	Motor type	Integrated Stepper - Rotating
Motor resolution	409600	Encoder type	H3 Serial/abs_multiturn
Speed [Rpm]	3000.00	Power Peak [W]	190.49
Flange size	NEMA 34 - 87x87mm	Shaft size - Front [mm]	9.52 mm
Running torque [Nm]	3.0	Rated Winding current [A]	9.0
Holding torque [Nm]	3.0	Connectivity: Without module	CANopen
Integrated PLC	Yes	PLC no. of DI/DO/AI	8
Closed loop	No	STO connector	No
Integrated gear	No	Gear ratio	
Brake	No	Protection House/Shaft	
Shaft Double	No	Main supply [V]	12-72
Main supply UL [V]	12-60	Voltage type - Main	DC



MIS340C12P6H385

Int.Step 12-72VDC, CANopen, AbsE

General information

Control voltage (CVI/O+) [VDC]	7-28		
Weight net [kg]	1.96	MTBF 100% [Year]	13
Weight gross [kg]	2.27	MTBF 30% [Year]	15
Software	MacTalk		
CE Marked	Yes		



Approval - ROHS-3	Yes		
--------------------------	-----	--	--



Approval UL	Yes		
--------------------	-----	--	--



Tariff no	85015100	Country Of Origin	DK
------------------	----------	--------------------------	----

Motion Information:

Velocity Precision [+/-ppm]		Velocity Resolution [Rpm]	
Acceleration / Deceleration Range [Rpm/s]		Acceleration / Deceleration Range [Rpm/s]	
Electronic Gearing Ratio [Range / Resolution]			



MIS340C12P6H385

Int.Step 12-72VDC, CANopen, AbsE

Mechanical information

Paint type

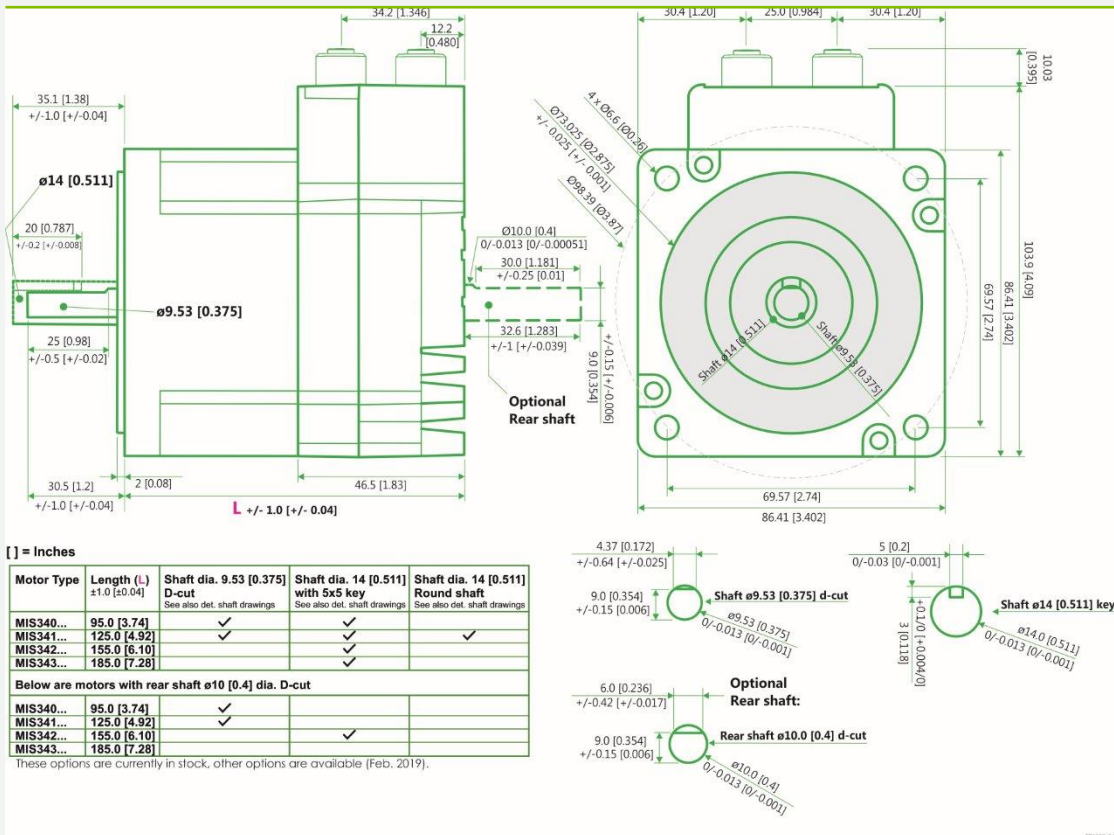

Motor length [mm]	95.0	Motor width [mm]	86.4
Motor height [mm]	104.0		
Protection house	IP42	Protection shaft	IP42
		Flange Rear	No
Flange Type Front		Flange Type Rear	
Motor diameter center front [mm]	73.0	Motor diameter center rear [mm]	
Bolt circle diameter front [mm]	98.4	Bolt circle diameter front [mm]	
Mounting holes front [mm]	6.6 mm	Mounting holes rear [mm]	
Flange Thickness [mm]		Flange material	Aluminium
		Shaft Double	No
Shaft Type Output	D-shape	Shaft Type Rear	
Shaft size - Front [mm]	9.52 mm	Shaft size - Rear	-
Shaft length Front [mm]	30.5	Shaft length Rear [mm]	
Shaft material	Stainless steel SUS303	Shaft Key included	Key NOT included
Shaft Key Dimension	-		
Integrated gear	No	Gear ratio	



MIS340C12P6H385

Int.Step 12-72VDC, CANopen, AbsE

Mechanical information

Gear efficiency [%]	-	Gear backlash [ArcMin]	-
Brake	No	Brake - Go ON time [ms]	-
Brake Holding torque [Nm]	-	Brake - Go OFF time [ms]	-
Rotor inertia [kgcm²]	1.4	Max inertia factor	30
Precision Motor - Absolute [Deg -/+]	0.15	Precision Motor - Max Load [Deg -/+]	
Precision Motor - Repeatability [Deg -/+]	0.15	Step angle [°/full step]	1.8°
CAD 2D [PDF]	Download	CAD 3D [STEP]	Download
CAD 2D [DWG]	Download	CAD 3D [DWG]	No
CAD 3D [EASM]	No	CAD 3D [IGES]	Download
Datasheet - pdf		CAD file page	Link
User Manual	Download	WEB page	Link
Approval UL	Yes	STO connector	No
Approval - ATEX	No	Approval TÜV - STO	No
Oil resistant			
Temperature ambient [°C]	0...40 °C and 0...70 °C with derating of performance	Temperature storage	-40...70 °C
Humidity working	5...93% non-condensing	Vibration	5-25 Hz: +/-1.6mm, 25-500Hz: 4G, 1.0 oct./min
Shock	15G, 30ms. 6 x 1000 cycles in +/-X, +/-Y, +/-Z	Withstand Voltage	500 VDC between earth and supply ground
EMC in general	EMC Directive DIR2014/30/EU	EMC Emission	EN61800-3 / EN61000-6-3 / EN61000-6-4 all 2. enviroment
EMC Immunity	En IEC 61800-3 / EN61000-6-1 all 2. enviroment	Safety in general	LVD DIR2014/35/EU / EL61800 - USA and Canada only MIS34x products are pending
Safety wo STO	EN60950-1	Safety w STO	EN60950-1 / EN61508-1/-2 SIL3 / ISO13849-1/-2 / ISO62061 / EN61800-5-1/-2
Inviromental	IEC 60068-2-27, Test Ea. Shock test	Inviromental 2	IEC 60068-2-6, Test Fc. Vibration test
Inviromental 3	IEC 60068-2-2, Test Bd. covers temperaturerise/dry heat	Inviromental 4	IEC 60068-2-78, Perm. moisture/Damp heat, steady state
REACH SVHC document	REACH-SVHC Statement	Low voltage Directive	LVD conformity with EU standard: EN 61800-3
No Dual Use			
Duty Cycle		Max Duty Cycle [%]	
Front bearing type	6002ZZCM/5K	Rear bearing type	6002ZZCM/5K
Axial Load Max: Typical Term	Axial load Max Typical is a run of 7.200.000 revolutions at indicated load	Axial Load Max: Long Term	Axial load Max Long is a run of 1.440.000.000 revolutions at indicated load
Axial Load Max: Typical [N] (Bearing)	1111	Axial Load Max: Long [N] (Bearing)	384



MIS340C12P6H385

Int.Step 12-72VDC, CANopen, AbsE

Mechanical information

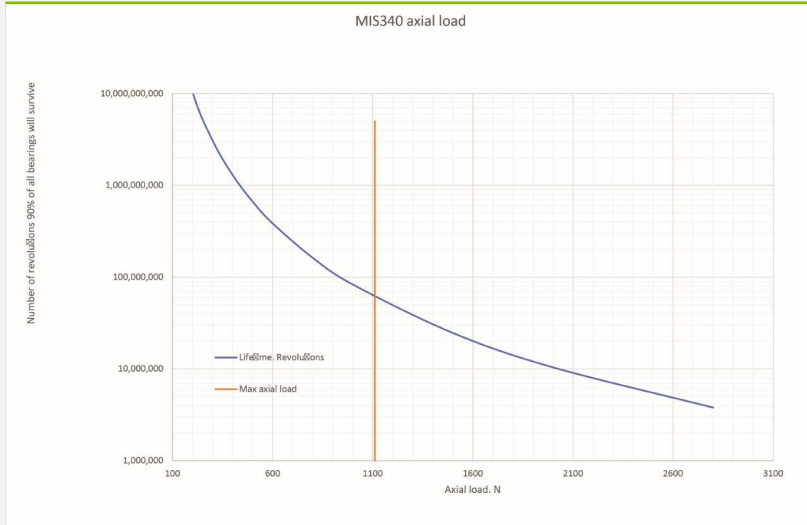

Radial Load Max Typical Term:	Radial load Max Typical is a run of 7.200.000 revolutions at indicated load	Radial Load Max Long Term:	Radial load Max Long is a run of 1.440.000.000 revolutions at indicated load
Radial Load Max: Typical [N] (Bearing)	760	Radial Load Max: Long [N] (Bearing)	372



Radial load distance [mm]	15	Axial play [mm]	
Axial play force [N]		Shaft Seal	



MIS340C12P6H385

Int.Step 12-72VDC, CANopen, AbsE

Connector information

Connector 1 label	PWR	Connector 1	M12 5-pin male A-coded
Connector 2 label	CN2	Connector 2	M12 5-pin female A-coded CAN
Connector 3 label	CN3	Connector 3	M12 5-pin female A-coded CAN
Connector 4 label	CN4	Connector 4	M12 17-pin female A-coded
Connector 1 RS485	No	Connector 2 RS485	No
Connector 3 RS485	No	Connector 4 RS485	Yes

Motor connectors

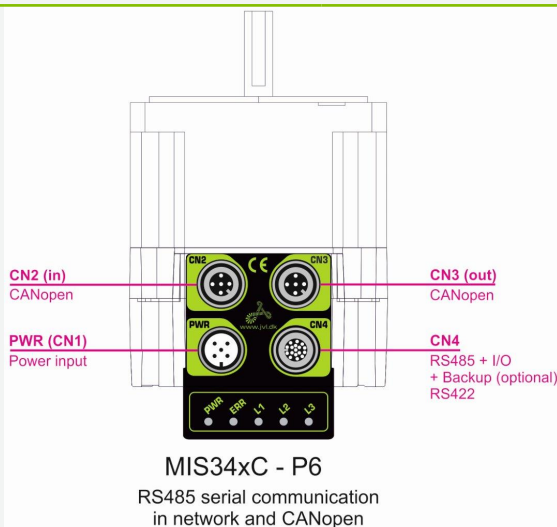

Picture CN1

"PWR" (CN1) - Power input. M12 - 5pin male connector				
Signal name	Description	Pin no.	JVL Cable WI1000-M12F5TxxN	Isolation group
P+	Main supply +7-72VDC. Connect with pin 2 *	1	Brown	1
P+	Main supply +7-72VDC. Connect with pin 1 *	2	White	1
P-	Main supply ground. Connect with pin 5 *	3	Blue	1
CVI	Control and user output supply +7-30VDC. DO NOT connect >30V to this terminal!	4	Black	1
P-	Main supply ground. Connect with pin 3 *	5	Grey	1

* Note: P+ and P- are each available at 2 terminals. Make sure that both terminals are connected in order to split the supply current in 2 terminals and thereby avoid an overload of the connector.

Picture CN2

CN2 - CANopen® interface. M12 - 5-pin female connector			
Signal name	Description	Pin no.	Cable: WI1006-M12F5SxxR
CAN_SHLD	Shield for the CAN interface - internally connected to the motor housing	1	Bare
CAN_V+	Reserved for future purpose - do not connect	2	Red
CAN_GND	CAN interface ground	3	Black
CAN_H	CAN interface. Positive signal line	4	White
CAN_L	CAN interface. Negative signal line	5	Blue



MIS340C12P6H385

Int.Step 12-72VDC, CANopen, AbsE

Connector information

Picture CN3

CN3 - CANopen® interface. M12 - 5-pin female connector			
Signal name	Description	Pin no.	Cable: WI1006-M12M5SxxR
CAN_SHLD	Shield for the CAN interface - internally connected to the motor housing	1	Bare
CAN_V+	Reserved for future purpose - do not connect	2	Red
CAN_GND	CAN interface ground	3	Black
CAN_H	CAN interface. Positive signal line	4	White
CAN_L	CAN interface. Negative signal line	5	Blue

Picture CN4

"CN4" - RS485 + I/O + Backup (option) connector - M12 - 17pin female connector				
Signal name	Description	Pin no.	JVL Cable WI1009M12 M17TxxN	Isolation group (see note)
IO1	I/O channel 1. Can be used as input or output	1	Brown	1
GND	Ground intended to be used together with the other signals in this connector	2	Blue	1
IO2	I/O channel 2. Can be used as input or output	3	White	1
IO3	I/O channel 3. Can be used as input or output	4	Green	1
RS422: B1-	RS422 I/O terminal B-	5	Pink	1
IO4	I/O channel 4. Can be used as input or output	6	Yellow	1
RS422: A1-	RS422 I/O terminal A-	7	Black	1
RS422: B1+	RS422 I/O terminal B+	8	Grey	1
CVO	Supply output. Connected internally to the CVI terminal in the PWR connector. DO NOT connect >30V to this terminal!	9	Red	1
RS422: A1+	RS422 I/O terminal A+	10	Violet	1
IO5	I/O channel 5. Can be used as input or output	11	Grey/pink	1
IO6	I/O channel 6. Can be used as input or output	12	Red/blue	1
IO7	I/O channel 7. Can be used as input or output	13	White/Green	1
IO8	I/O channel 8. Can be used as input or output	14	Brown/Green	1
RS485: B0-	RS485 interface. Leave open if unused	15	White/Yellow	1
EXTBACKUP	Only for motors with the -H3 or -H4 option (abs. multiturn encoder). This terminal can be connected to an external supply. Connect to ground (GND) if not used.	16	Yellow/brown	1
RS485: A0+	RS485 interface. Leave open if unused	17	White/grey	1

* Note: Isolation group indicate which terminals/circuits that a galvanic connected to each other. In other words group 1, 2, 3 and 4 are all fully independently isolated from each other. Group 1 correspond to the housing of the motor which may also be connected to earth via the DC or AC input supply.

Connector STO No

Picture STO Con -



MIS340C12P6H385

Int.Step 12-72VDC, CANopen, AbsE

Torque, force and Power information

Supply Volt 1 [V]	12	Power Peak 1 [W]	43.96
Supply Volt 2 [V]	24	Power Peak 2 [W]	84.88
Supply Volt 3 [V]	48	Power Peak 3 [W]	170.29
Supply Volt 4 [V]	72	Power Peak 4 [W]	190.49
Holding torque [Nm]	3.0	Running torque [Nm]	3.0
Detent torque [Nm]			

MIS340 motor torque and shaft power versus speed

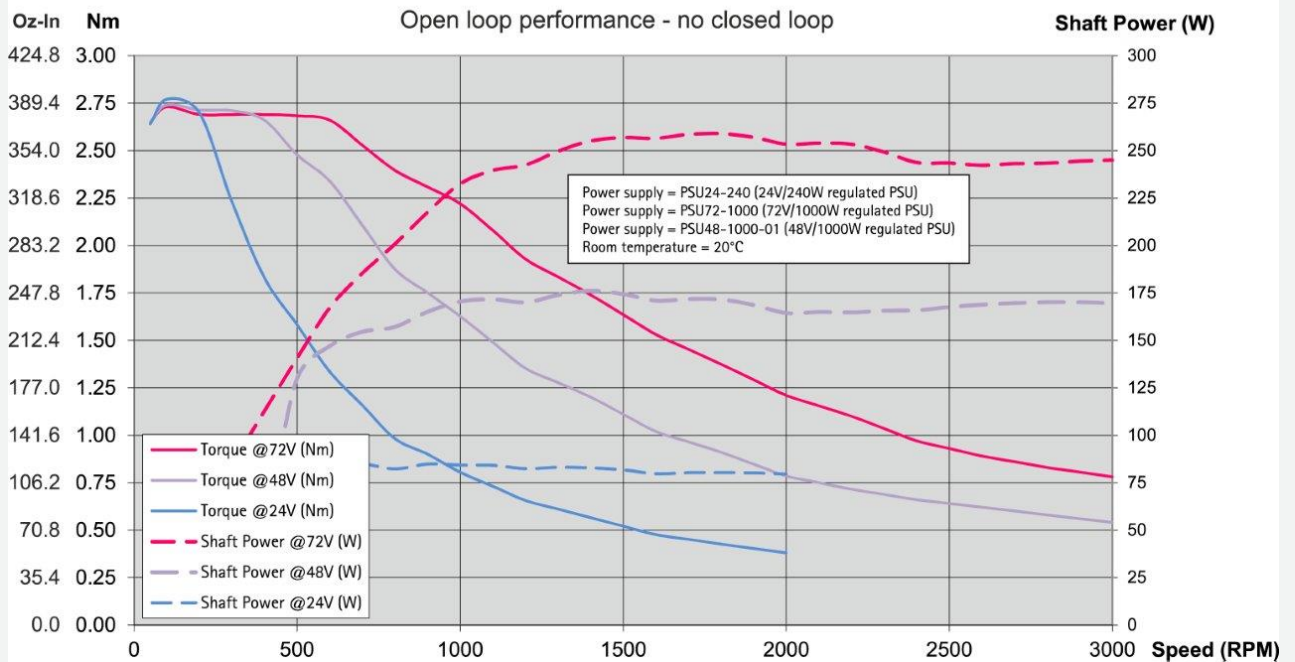



MIS340C12P6H385

Int.Step 12-72VDC, CANopen, AbsE

Electrical information

Main supply [V]	12-72	Main supply Min-Max [V]	7-90
Main supply UL [V]	12-60	Main supply Max UL [V]	7-60
Rated motor current [A]	6.3	Control voltage (CVI/O+) [VDC]	7-28
Control Voltage (CVI) Min-Max [VDC]	7-32	CVI current wo Ethernet and output (12/24VDC) [mA]	
Current Ethernet option (12/24VDC) [mA]		Current brake option [mA]	-
Current for 1 Dig. output - 350 max [mA]		Max current CVI [A]	
Dig. Input impedans	27 Kohm	Counter frequency max	12MHz
MTBF 30% [Year]	15	MTBF 100% [Year]	13
Motor resolution	409600	Encoder type	H3 Serial/abs_multiturn
Encoder Resolution (H2)	N0 - No encoder	Encoder Resolution (H3)	H3 - 1024 Multiturn AbsEnc
Encoder revolutions	+/-5242	PLC no. of DI/DO/AI	8
Analogue voltage	0-5VDC 12bit		
Standard used		Standard used 2	
Resistance [Ohm]		Induction [mH]	



MIS340C12P6H385

Int.Step 12-72VDC, CANopen, AbsE

Communication information

Software	MacTalk	Connector 2 RS485	No
Connectivity: Without module	CANopen	Connector 3 RS485	No
		Connector 4 RS485	Yes

Motor connectors

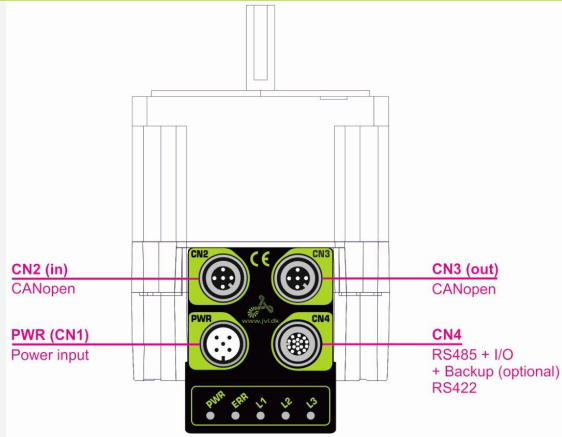

MIS34xC - P6
RS485 serial communication
in network and CANopen

e-PLC Files

Ethernet, PLC demo files



MIS340C12P6H385

Int.Step 12-72VDC, CANopen, AbsE

Cable information

Item number	Mount on	Cable con 1 +Con 1 angle	Cable application	Wires no totally	Cable length [m]
Item description		Cable con 2 +Con 2 angle	Cable flexibility	Wire [mm2]	Connector 1 LED
WI1000-M12F5T02N M12 Shl Cable 2m 5 pin Fem 0°, Power	Connector 1	M12 5-pin female A-coded - 180° Straight Open Ended - n/a	Power/Motor/com Standard	5 0.32	2 No
WI1000-M12F5T05N M12 Shl Cable 5m 5 pin Fem 0°, Power	Connector 1	M12 5-pin female A-coded - 180° Straight Open Ended - n/a	Power/Motor/com Standard	5 0.32	5 No
WI1000-M12F5T1.2N M12 Shl Cable 1.2m 5 pin Fem 0°, Power	Connector 1	M12 5-pin female A-coded - 180° Straight Open Ended - n/a	Power/Motor/com Standard	5 0.32	1.2 No
WI1000-M12F5T10N M12 Shl Cable 10m 5 pin Fem 0°, Power	Connector 1	M12 5-pin female A-coded - 180° Straight Open Ended - n/a	Power/Motor/com Standard	5 0.32	10 No
WI1000-M12F5T10R M12 Shl Cable 10m 5 pin Fem 0°, Power, High-flex	Connector 1	M12 5-pin female A-coded - 180° Straight Open Ended - n/a	Power/Motor/com Cable Chains - 2D	5 0.34	10 No
WI1000-M12F5T20N M12 Shl Cable 20m 5 pin Fem 0°, Power	Connector 1	M12 5-pin female A-coded - 180° Straight Open Ended - n/a	Power/Motor/com Standard	5 0.32	20 No
WI1000-M12F5TLT0185 M12 shl Cable 3m 5 pin female 0°,PW SPEC	Connector 1	M12 5-pin female A-coded - 180° Straight - n/a	Power/Motor/com Standard	5 0.32	3 No
WI1000-M12F5TM5T1.5N M12 A Code Shl Cable 1.5m 5 pin Female/Male 0° Pow	Connector 1	M12 5-pin female A-coded - 180° Straight - n/a	Power/Motor/com		1.5 No
WI1000-M12F5V05N M12 Shl Cable 5m 5 pin Fem 90°, Power	Connector 1	M12 5-pin female A-coded - 90° Angled Open Ended - n/a	Power/Motor/com Standard	5 0.32	5 No
WI1000-M12F5V05R M12 Shl Cable 5m 5 pin Fem 90°, Power, 3D	Connector 1	M12 5-pin female A-coded - 90° Angled - n/a	Power/Motor/com		5 No
WI1000-M12F5V10N M12 Shl Cable 10 m 5 pin Fem 90°, Power	Connector 1	M12 5-pin female A-coded - 90° Angled Open Ended - n/a	Power/Motor/com Standard	5 0.32	10 No
WI1000-M12F5V20N M12 Shl Cable 20m 5 pin Fem 90°, Power	Connector 1	M12 5-pin female A-coded - 90° Angled Open Ended - n/a	Power/Motor/com Standard	5 0.32	20 No
WI1000-M12F5W05N M12 Shl Cable 5m LED 5p Fem 90°, Power <50V	Connector 1	M12 5-pin female A-coded - 90° Angled Open Ended - n/a	Power/Motor/com Standard	5 0.32	5 LED
WI1000-M12F5W10N M12 Shl Cable 10m LED 5 p Fem 90°, Power <50V	Connector 1	M12 5-pin female A-coded - 90° Angled Open Ended - n/a	Power/Motor/com Standard	5 0.32	10 LED
WI1000-M12F5W15N M12 Shl Cable 15m LED 5 p Fem 90°, Power <50V	Connector 1	M12 5-pin female A-coded - 90° Angled Open Ended - n/a	Power/Motor/com Standard	5 0.32	15 LED
WI1000-M12F5W20N M12 Shl Cable 20m LED 5 p Fem 90°, Power <50V	Connector 1	M12 5-pin female A-coded - 90° Angled Open Ended - n/a	Power/Motor/com Standard	5 0.32	20 LED
WI1000-M12F5WF5W20N M12 shl cab 20m LED 5 pin female 90',Pow <50V	Connector 1	M12 5-pin female A-coded - 90° Angled M12 5-pin female A-coded - n/a	Power/Motor/com Standard	5 0.32	20 LED
WI1005-M12F5TF5T03P M12 Cab 3m, 5p Fem - 5p Fem twistedPair	Connector 1	M12 5-pin female A-coded - 180° Straight M12 5-pin female A-coded - n/a	Communication		3 No
WI1005-M12F5TM5T2.0N M12 cable 2m, 5 pin female - 5pin male	Connector 1	M12 5-pin female A-coded - 180° Straight M12 5-pin male A-coded - n/a	Communication Standard		2 0.32 No
WI1008-M12F5AG1 M12 Con 5p Fem 90° Spring Ø4-8mm cable	Connector 1	M12 5-pin female A-coded - 90° Angled Open Ended - n/a	CANopen/DeviceNet		20 No
WI1008-M12F5SS1 M12 Con 5p Fem 0° Solder assembly	Connector 1	M12 5-pin female A-coded - 180° Straight - n/a	CANopen/DeviceNet n/a	n/a	Connector No
WI1008-M12F5TG1 M12 Con 5p Fem 0° Spring Shield+B222	Connector 1	M12 5-pin female A-coded - 180° Straight - n/a	CANopen/DeviceNet n/a	n/a	Connector No
WI1008-M12F5VG1 M12 Con 5p Fem 90° Spring Shield	Connector 1	M12 5-pin female A-coded - 90° Angled - n/a	CANopen/DeviceNet n/a	n/a	Connector No
WI1025-M12F5AF5AM5A M12 T-Con 2x Fem 5 p + 1x Male 5 p	Connector 1	M12 5-pin female A-coded - 90° Angled M12 5-pin female A-coded - n/a		5 0.32	No
WI1025-M12F5AM5A M12 Cabinet Feed-through F5p-M5p	Connector 1	M12 5-pin female A-coded - 90° Angled M12 5-pin male A-coded - n/a		5 0.32	No
WI1025-M12F5AM5AF5A M12 T-Con Fem 5p+ Male 5p + Fem 5p NoSh	Connector 1	M12 5-pin female A-coded - 90° Angled M12 5-pin male A-coded - n/a		5 0.32	No
WI1025-M12F5VM5VF5V M12 Shl Y-Con 1xMale 5p + 2x Fem 5p CAN	Connector 1	M12 5-pin female A-coded - 90° Angled M12 5-pin male A-coded CAN - n/a		5 0.32	No
WI1006-M12M5S05R	Connector 2	M12 5-pin male A-coded CAN - 180° Straight	CANopen/DeviceNet	4	5



MIS340C12P6H385

Int.Step 12-72VDC, CANopen, AbsE

Cable information

Item number	Mount on	Cable con 1 +Con 1 angle	Cable application	Wires no totally	Cable length [m]
Item description		Cable con 2 +Con 2 angle	Cable flexibility	Wire [mm2]	Connector 1 LED
M12 5m 5p Male 0° CAN Twisted pair		Open Ended - n/a	Robotic - 3D	0.32 + 0.2	No
WI1006-M12M5S05T	Connector 2	M12 5-pin male A-coded CAN - 180° Straight	CANopen/DeviceNet 4		5
M12 5m 5p Male 0° CAN Twisted pair		Open Ended - n/a	Standard	0.32 + 0.2	No
WI1006-M12M5S15R	Connector 2	M12 5-pin male A-coded CAN - 180° Straight	CANopen/DeviceNet 4		15
M12 15m 5p Male 0° CAN Twisted pair		Open Ended - n/a	Robotic - 3D	0.32 + 0.2	No
WI1006-M12M5T05N	Connector 2	-	CANopen/DeviceNet		
M12 5m 5p Male 0° CAN/DeviceNet		-			
WI1006-M12M5TM5T.3N	Connector 2	M12 5-pin male A-coded CAN - 180° Straight	CANopen/DeviceNet 4		0.3
M12 0.3m 5p Male/Male 0° CAN Twisted pair		M12 5-pin male A-coded CAN - n/a	Standard	0.32 + 0.2	No
WI1006-M12M5TM5T01N	Connector 2	M12 5-pin male A-coded CAN - 180° Straight	CANopen/DeviceNet 4		1
M12 1m 5p Male/Male 0° CAN Twisted pair		M12 5-pin male A-coded CAN - n/a	Standard	0.32 + 0.2	No
WI1006-M12M5TM5T02N	Connector 2	M12 5-pin male A-coded CAN - 180° Straight	CANopen/DeviceNet 4		2
M12 2m 5p Male/Male 0° CAN Twisted pair		M12 5-pin male A-coded CAN - n/a	Standard	0.32 + 0.2	No
WI1006-M12M5TM5T03N	Connector 2	M12 5-pin male A-coded CAN - 180° Straight	CANopen/DeviceNet 4		3
M12 3m 5p Male/Male 0° CAN Twisted pair		M12 5-pin male A-coded CAN - n/a	Standard	0.32 + 0.2	No
WI1006-M12M5TM5T05N	Connector 2	M12 5-pin male A-coded CAN - 180° Straight	CANopen/DeviceNet 4		5
M12 5m 5p Male/Male 0° CAN Twisted pair		M12 5-pin male A-coded CAN - n/a	Standard	0.32 + 0.2	No
WI1006-M12M5TM5T1.7N	Connector 2	M12 5-pin male A-coded CAN - 180° Straight	CANopen/DeviceNet 4		1.7
M12 1.7m 5p Male/Male 0° CAN Twisted pair		M12 5-pin male A-coded CAN - n/a	Standard	0.32 + 0.2	No
WI1006-M12M5TM5T20N	Connector 2	M12 5-pin male A-coded CAN - 180° Straight	CANopen/DeviceNet 4		20
M12 20m 5p Male/Male 0° CAN Twisted pair		M12 5-pin male A-coded CAN - n/a	Standard	0.32 + 0.2	No
WI1008-M12M5STR4	Connector 2	M12 5-pin male A-coded - 180° Straight	CANopen/DeviceNet n/a		Connector
M12 Con 5-pin male A Code Resistor CAN		- n/a	n/a	n/a	No
WI1006-M12M5S05R	Connector 3	M12 5-pin male A-coded CAN - 180° Straight	CANopen/DeviceNet 4		5
M12 5m 5p Male 0° CAN Twisted pair		Open Ended - n/a	Robotic - 3D	0.32 + 0.2	No
WI1006-M12M5S05T	Connector 3	M12 5-pin male A-coded CAN - 180° Straight	CANopen/DeviceNet 4		5
M12 5m 5p Male 0° CAN Twisted pair		Open Ended - n/a	Standard	0.32 + 0.2	No
WI1006-M12M5S15R	Connector 3	M12 5-pin male A-coded CAN - 180° Straight	CANopen/DeviceNet 4		15
M12 15m 5p Male 0° CAN Twisted pair		Open Ended - n/a	Robotic - 3D	0.32 + 0.2	No
WI1006-M12M5T05N	Connector 3	-	CANopen/DeviceNet		
M12 5m 5p Male 0° CAN/DeviceNet		-			
WI1006-M12M5TM5T.3N	Connector 3	M12 5-pin male A-coded CAN - 180° Straight	CANopen/DeviceNet 4		0.3
M12 0.3m 5p Male/Male 0° CAN Twisted pair		M12 5-pin male A-coded CAN - n/a	Standard	0.32 + 0.2	No
WI1006-M12M5TM5T01N	Connector 3	M12 5-pin male A-coded CAN - 180° Straight	CANopen/DeviceNet 4		1
M12 1m 5p Male/Male 0° CAN Twisted pair		M12 5-pin male A-coded CAN - n/a	Standard	0.32 + 0.2	No
WI1006-M12M5TM5T02N	Connector 3	M12 5-pin male A-coded CAN - 180° Straight	CANopen/DeviceNet 4		2
M12 2m 5p Male/Male 0° CAN Twisted pair		M12 5-pin male A-coded CAN - n/a	Standard	0.32 + 0.2	No
WI1006-M12M5TM5T03N	Connector 3	M12 5-pin male A-coded CAN - 180° Straight	CANopen/DeviceNet 4		3
M12 3m 5p Male/Male 0° CAN Twisted pair		M12 5-pin male A-coded CAN - n/a	Standard	0.32 + 0.2	No
WI1006-M12M5TM5T05N	Connector 3	M12 5-pin male A-coded CAN - 180° Straight	CANopen/DeviceNet 4		5
M12 5m 5p Male/Male 0° CAN Twisted pair		M12 5-pin male A-coded CAN - n/a	Standard	0.32 + 0.2	No
WI1006-M12M5TM5T1.7N	Connector 3	M12 5-pin male A-coded CAN - 180° Straight	CANopen/DeviceNet 4		1.7
M12 1.7m 5p Male/Male 0° CAN Twisted pair		M12 5-pin male A-coded CAN - n/a	Standard	0.32 + 0.2	No
WI1006-M12M5TM5T20N	Connector 3	M12 5-pin male A-coded CAN - 180° Straight	CANopen/DeviceNet 4		20
M12 20m 5p Male/Male 0° CAN Twisted pair		M12 5-pin male A-coded CAN - n/a	Standard	0.32 + 0.2	No
WI1008-M12M5STR4	Connector 3	M12 5-pin male A-coded - 180° Straight	CANopen/DeviceNet n/a		Connector
M12 Con 5-pin male A Code Resistor CAN		- n/a	n/a	n/a	No
WI1005-M12M17SAA01	Connector 4	M12 17-pin male A-coded - 180° Straight	Communication	n/a	Connector
M12 17-pin male Axis 1 Without wire		n/a - n/a	n/a	n/a	No
WI1005-M12M17SAA01W	Connector 4	M12 17-pin male A-coded - 180° Straight	Communication	n/a	Connector
M12 17-pin male Axis 1, with wire 1,2m		n/a - n/a	n/a	n/a	No
WI1005-M12M17SAA02	Connector 4	M12 17-pin male A-coded - 180° Straight	Communication	n/a	Connector
M12 17-pin male Axis 2 Without wire		n/a - n/a	n/a	n/a	No
WI1005-M12M17SAA03	Connector 4	M12 17-pin male A-coded - 180° Straight	Communication	n/a	Connector
M12 17-pin male Axis 3 Without wire		n/a - n/a	n/a	n/a	No



MIS340C12P6H385

Int.Step 12-72VDC, CANopen, AbsE

Cable information

Item number	Mount on	Cable con 1 +Con 1 angle	Cable application	Wires no totally	Cable length [m]
Item description		Cable con 2 +Con 2 angle	Cable flexibility	Wire [mm2]	Connector 1 LED
WI1005-M12M17SAA04 M12 17-pin male Axis 4 Without wire	Connector 4	M12 17-pin male A-coded - 180° Straight n/a - n/a	Communication n/a	n/a n/a	Connector No
WI1005-M12M17SAA05 M12 17-pin male Axis 5 Without wire	Connector 4	M12 17-pin male A-coded - 180° Straight n/a - n/a	Communication n/a	n/a n/a	Connector No
WI1005-M12M17SAA06 M12 17-pin male Axis 6 Without wire	Connector 4	M12 17-pin male A-coded - 180° Straight n/a - n/a	Communication n/a	n/a n/a	Connector No
WI1005-M12M17SAA06W M12 17-pin male Axis 6 with wire 1,2m	Connector 4	M12 17-pin male A-coded - 180° Straight n/a - n/a	Communication n/a	n/a n/a	Connector No
WI1005-M12M17SAA07 M12 17-pin male Axis 7 Without wire	Connector 4	M12 17-pin male A-coded - 180° Straight n/a - n/a	Communication n/a	n/a n/a	Connector No
WI1005-M12M17SAA08 M12 17-pin male Axis 8 Without wire	Connector 4	M12 17-pin male A-coded - 180° Straight n/a - n/a	Communication n/a	n/a n/a	Connector No
WI1005-M12M17SAA09 M12 17-pin male Axis 9 Without wire	Connector 4	M12 17-pin male A-coded - 180° Straight n/a - n/a	Communication n/a	n/a n/a	Connector No
WI1005-M12M17SAA10 M12 17-pin male Axis 10 Without wire	Connector 4	M12 17-pin male A-coded - 180° Straight n/a - n/a	Communication n/a	n/a n/a	Connector No
WI1008-M12M17SR1 M12 Con 17p Male 0° Metal housing 5.4-8.2mm cable	Connector 4	M12 17-pin male A-coded - 180° Straight - n/a	CANopen/DeviceNet n/a	n/a n/a	Connector No
WI1009-M12M17T01N M12 Shl Cable 1m 17p Mal 0° MISxx,Ex41 twisted	Connector 4	M12 17-pin male A-coded - 180° Straight Open Ended - n/a	Basic I/O, Com Standard	17 0.061	1 No
WI1009-M12M17T05N M12 Shl Cable 5m 17p Mal 0° MISxx,Ex41 twisted	Connector 4	M12 17-pin male A-coded - 180° Straight Open Ended - n/a	Basic I/O, Com Standard	17 0.061	5 No
WI1009-M12M17T10R M12 Shl Cable 10m 17p Mal 0° MISxx,Ex41 twisted	Connector 4	M12 17-pin male A-coded - 180° Straight Open Ended - n/a	Basic I/O, Com Robotic - 3D	17 0.061	5 No
WI1009-M12M17T20N M12 Shl Cable 20m 17p Mal 0° MISxx,Ex41 twisted	Connector 4	M12 17-pin male A-coded - 180° Straight Open Ended - n/a	Basic I/O, Com Standard	17 0.061	20 No
WI1009-M12M17TF17T.5 M12 Shl Cable.5m Male17p0°-Female 17p0° twist pair	Connector 4	M12 17-pin male A-coded - 180° Straight M12 17-pin female A-coded - n/a	Basic I/O, Com Standard	17 0.061	0.5 No
WI1009-M12M17TF17T01 M12 Shl Cable 1m Male17p0°-Female 17p0° twist pair	Connector 4	M12 17-pin male A-coded - 180° Straight M12 17-pin female A-coded - n/a	Basic I/O, Com Standard	17 0.061	1 No
WI1009-M12M17TF17T02 M12 Shl Cable 2m Male17p0°-Female 17p0° twist pair	Connector 4	M12 17-pin male A-coded - 180° Straight M12 17-pin female A-coded - n/a	Basic I/O, Com Standard	17 0.061	2 No
WI1009-M12M17TF17T03 M12 Shl Cable 3m Male17p0°-Female 17p0° twist pair	Connector 4	M12 17-pin male A-coded - 180° Straight M12 17-pin female A-coded - n/a	Basic I/O, Com Standard	17 0.061	3 No
WI1009-M12M17TF17T04 M12 Shl Cable 4m Male17p0°-Female 17p0° twist pair	Connector 4	M12 17-pin male A-coded - 180° Straight M12 17-pin female A-coded - n/a	Basic I/O, Com Standard	17 0.061	4 No
WI1009-M12M17V05N M12 Shl Cable 5m 17p Mal 90° MISxx,Ex41 twisted	Connector 4	M12 17-pin male A-coded - 90° Angled Open Ended - n/a	Basic I/O, Com Standard	17 0.061	5 No
WI1009-M12M17V05R M12 Shl Cable 5m 17p Mal 90° MISxx,Ex41 twisted	Connector 4	M12 17-pin male A-coded - 90° Angled - n/a	Basic I/O, Com Robotic - 3D	17 0.061	5 No
WI1009-M12M17V10N M12 Shl Cable 10m 17p Mal 90° MISxx,Ex41 twisted	Connector 4	M12 17-pin male A-coded - 90° Angled Open Ended - n/a	Basic I/O, Com Standard	17 0.061	10 No
RS485-M12-1-5-17 RS485 M12-17pin DSub, 5m v1.1	Connector 4 RS485	-	-	-	-

NOTES:

1. Operation Modes : Passive, Position, Gear, Velocity, Zero search mode type 1, type 2 and torque, Cyclic Synchronous Position mode (CSP)
2. Tolerance for torque and power is $\pm 10\%$.
3. Shaft - AISI 303 Stainless steel.
4. Encoder Type: Internal, magnetic, absolute 1 rev. Closed loop ready. Resolution per rev.: 4096 counts / 1024 lines (quadrature output).

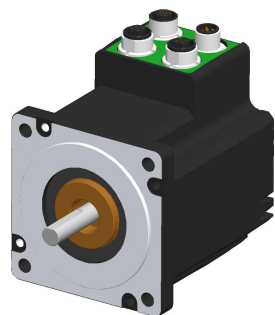
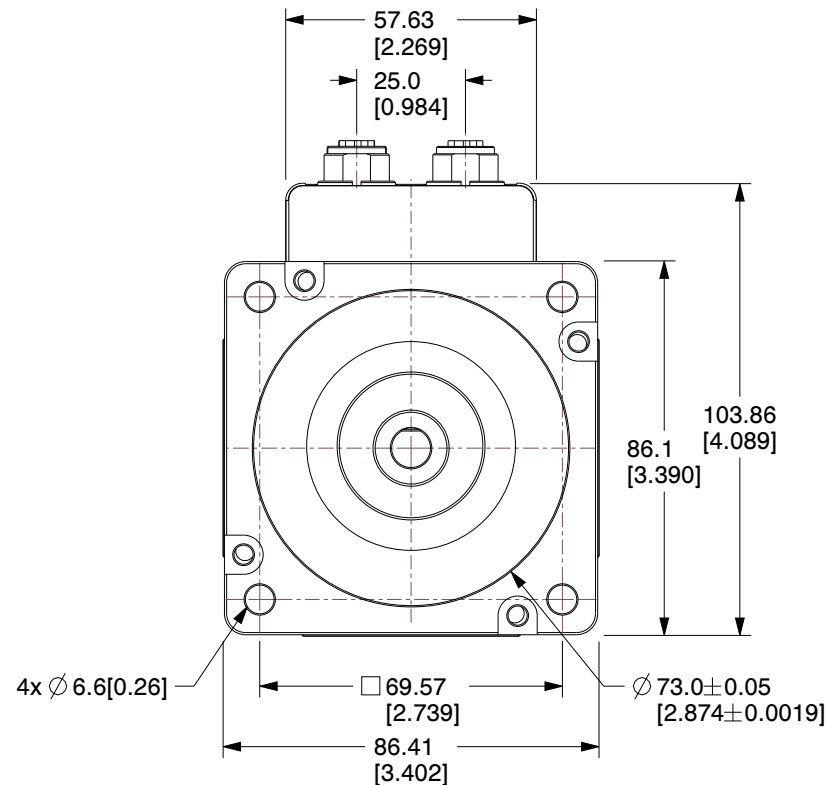
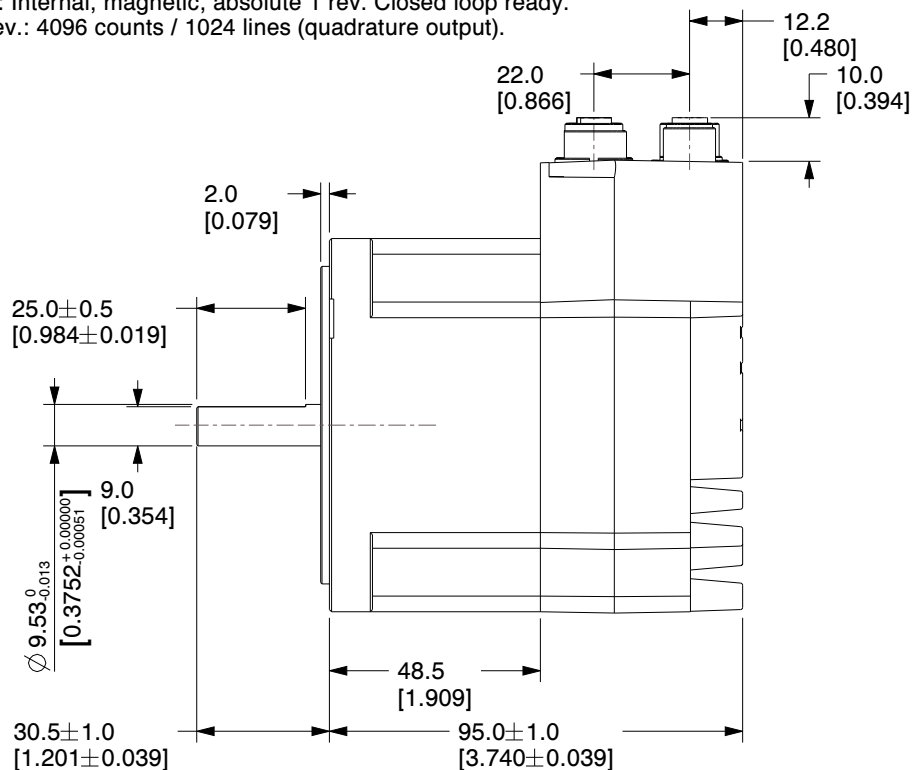

MOTOR SPECIFICATIONS

Running Torque	3.0 Nm	Main Supply Volt.(P+) (nominal)	+ 7-72VDC
Power(watt) @72VDC	190.49	Control Voltage (CVI)	+ 7-28VDC
Velocity (range)	0.01 to 3000.00 RPM	Resolution	409600 cnt/rev
Velocity (resolution)	0.01 RPM	Protection	Shaft: IP42, Motor: IP42
Velocity (precision)	± 50 ppm	Supply Voltage	SMC85 Controller 12-72VDC
Accel./Deceleration (range)	1 - 500000 RPM/s	Connection	2xCANopen, 8xIOA/RS422 + 485
Accel./Deceleration (resolution)	1 RPM/s	Storage temp.	-20 to + 85°C. (-4 to 185 °F)
Electronic Gearing (range/resolution)	1/409600 up to 409600/1	Operating Temperature	Ambient 0 to + 40°C (32-104°F)
Inertia	1.4 kgcm ²	Connector Type	Radial Connector
Max. axial shaft force	115N	Weight	2.1 kg
Max. radial shaft force	180 N applied 12.5mm from shaft end	Analogue Input (Number/Resolution)	8 inputs available / 12 Bit. (0 to + 5.00 VDC)

JVL A/S

Bregnerødvej 127
DK-3460 Birkerød
Denmark



JVL
www.jvl.dk

PART NUMBER:

MIS340C12P6H285

PART DESCRIPTION:

Integrated Stepper Motor



A4

SCALE	NTS
UNIT	MM [Inch]

Unless specifically stated otherwise, this drawing is the property of JVL A/S and no feature embodied herein may be disclosed except as previously authorized