



MAC141-A1AAAA-A009

Int.Servo.AC 134WS1 0.48Nm IP42 Inc G2 conn.

MAC motorĚ is a series of integrated (all-in-one) servo motors with shaft power from 46 W to 4500 W. +400 W and new F-series (50..140 W) are programmable through ePLC (embedded-PLC). Choose between a large number of control modules.

Options include:

- Absolute Multiturn Encoder (incremental encoder is standard)
- Built-in Brake or Brake module (MABxx)
- Ethernet module w/built-in Switch for easy daisy-chaining and all protocols (Profinet, EtherNet/IP, EtherCAT, SERCOS, ModbusTCP/UDP, Powerlink)
- Wireless modules are also available: WLAN or BlueTooth
- CANopen, Devicenet or Profibus or ePLC modules
- Serial communication modules, RS232 and/or RS485
- High IP versions are also available (IP 65..66..67)
- Food or Medico types in Stainless Steel IP69K

Unique Ethernet functionality: use MacTalkĚ (PC software) to change freely between all the different Ethernet protocols, you dont need several different types on stock Ě ONE is enough.



General information

Description	Int.Servo.AC 134WS1 0.48Nm IP42 Inc G2 conn., WxHxL: 59x59x172 mm. 2700 RPM @ 48VDC - 1350 RPM @ 24VDC. 0.48 Nm/1.59 Nm, IP42, Incremental Encoder: 4096 CPR, Color: Black, Ø6.35x20.5 mm D-shape, w/Gen. 2 connector f/Ethernet modules Ex4, ie. EtherCAT, EtherNet/IP, Profinet, ModbusTCP etc		
Manufacture	JVL	Motor type	Integr. AC-servo - Rotating
Motor power [W]	134	Power Peak [W]	402
Duty Cycle	S1	Max Duty Cycle [%]	100
Continuous Torque	0.48	Peak torque [Nm]	1.59
Main supply [V]	12-48	Voltage type - Main	DC
Speed [Rpm]	2700	Connectivity: Without module	RS232 - 5VDC, Modbus RTU
Encoder type	Incr. Encoder	Encoder [Counts/rev]	4096
Integrated PLC	No	Brake	No
STO connector	No	Fan mounted	No
Integrated gear	No	Gear ratio	-
Approval - UL	No	Approval TÜV - STO	No
PLC no. of AIN	1	PLC no. of DI	-



JVL A/S | Bregnerødvej 127 | DK-3460 Birkerød | Denmark | Tel. (+45) 4582 4440 | www.jvl.dk | sales@jvl.dk

MAC141-A1AAAA-A009

Int.Servo.AC 134WS1 0.48Nm IP42 Inc G2 conn.

General information

PLC no. of DIO	-	PLC no. of DO	2
Multifunction IOs	1		
Flange size	NEMA 23 - 58.7x58.7mm	Protection house	IP42
Shaft size - Front [mm]	6.35mm	Protection shaft	IP42
Color	Black	Paint type	
Ambient Temperature range:		Max. Amb. Temperature range - Torque derating:	
Maximum Installation Altitude:		Max. Installation Altitude - Power Derating every 1000m:	
Weight net [kg]	1.32	Weight gross [kg]	1.49
Tariff no	85015100	Country Of Origin	DK



MAC141-A1AAAA-A009

Int.Servo.AC 134WS1 0.48Nm IP42 Inc G2 conn.

Mechanical information

Motor type	Integr. AC-servo - Rotating	Color	Black
Rotor inertia [kgcm²]	0.227	Max inertia factor	20
Encoder type	Incr. Encoder	Encoder [Counts/rev]	4096
Precision Motor - Absolute [Deg -/+]	0.087	Precision Motor - Max Load [Deg -/+]	
Precision Motor - Repeatability [Deg -/+]	0.087		
Brake	No	Brake - Go ON time [ms]	-
Brake Holding torque [Nm]	-	Brake - Go OFF time [ms]	-
Radial load [N]	75	Radial load distance [mm]	20
Axial load [N]	15		
Axial play [mm]	+/-0.05	Axial play force [N]	xxx
Front bearing type	608ZZ	Rear bearing type	607ZZ
Integrated gear	No	Gear ratio	-
Gear efficiency [%]	-	Gear backlash [ArcMin]	-
Motor length [mm]	172.0	Motor width [mm]	59.0
Motor height [mm]	59.0	Protection house	IP42
Customer Sealing	Standard		
Flange size	NEMA 23 - 58.7x58.7mm	Mounting holes front [mm]	5.2
Motor diameter center front [mm]	38.1	Bolt circle diameter front [mm]	66.6
Flange material	Aluminium painted Black	Flange Thickness [mm]	
Shaft Key included	-	Shaft Key Dimension	-
Shaft size - Front [mm]	6.35mm	Protection shaft	IP42
Shaft length Front [mm]	20.5	Shaft material	Steel
Approval - ROHS-3	Yes	Approval - UL	No
Approval TÜV - STO	No	Approval - ATEX	No
CAD 2D [PDF]	Download	CAD 3D [STEP]	Download
CAD 2D [DWG]	Download	CAD 3D [DWG]	Download



MAC141-A1AAAA-A009

Int.Servo.AC 134WS1 0.48Nm IP42 Inc G2 conn.

Mechanical information

CAD 3D [EASM]	No	CAD 3D [IGES]	Download
Datasheet - pdf	Yes	User Manual	Download
REACH SVHC document	Download	Low voltage Directive	LVD conformity with EU standard: EN 61800-3
No Dual Use	-		

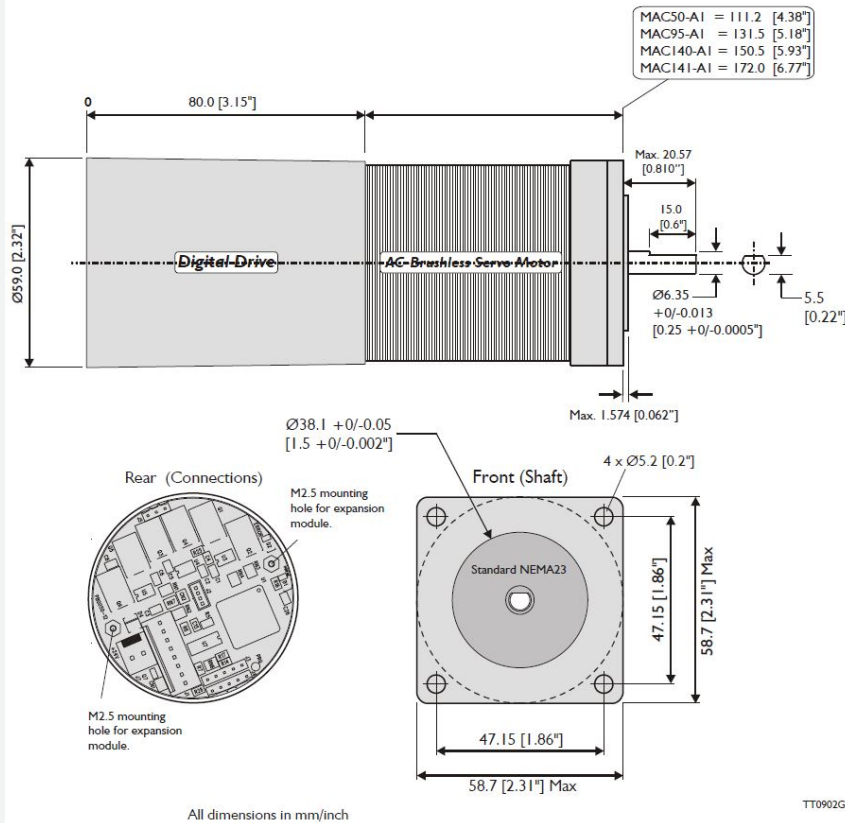

Shaft Seal



MAC141-A1AAAA-A009

Int.Servo.AC 134WS1 0.48Nm IP42 Inc G2 conn.

Connector information

Motor connectors

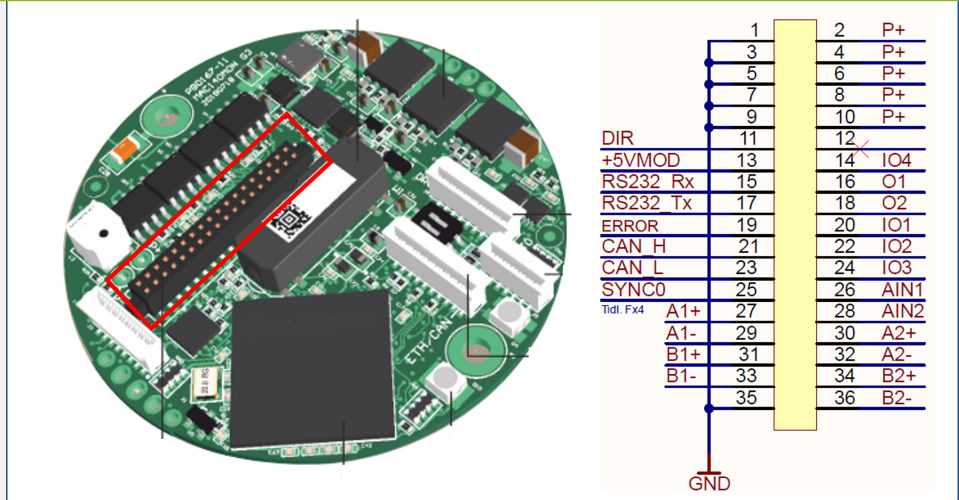

Expansion connector	Generation 2 Limited		
PLC no. of DI	-	PLC no. of DO	2
PLC no. of DIO	-	PLC no. of AIN	1
Multifunction IOs	1		
Connector Power	Molex 2-pin Power	Connector Power Supplier	
Connector Power direction	Straight		
Connector PDO	No	Connector PDO Supplier	
Connector STO	No		
Module connections	Here - Click for module cable connections		



MAC141-A1AAAA-A009

Int.Servo.AC 134WS1 0.48Nm IP42 Inc G2 conn.

Torque, force and Power information

RMS torque [Nm]	0.48	Peak torque [Nm]	1.59
Supply Volt 1 [V]	12	Supply Volt 2 [V]	24
Supply Volt 3 [V]	48	Supply Volt 4 [V]	-

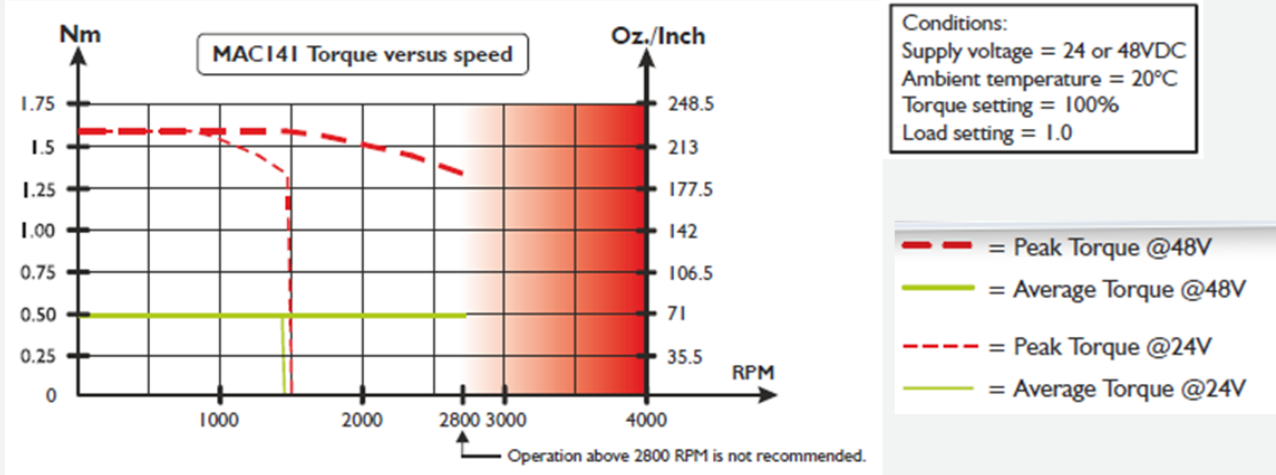



MAC141-A1AAAA-A009

Int.Servo.AC 134WS1 0.48Nm IP42 Inc G2 conn.

Electrical information

Control voltage (CVI/O+) [VDC]	12-28	Control Voltage (CVI) Min-Max [VDC]	12-30
Main supply [V]	12-48	Main supply Min-Max [V]	10-50
Voltage type - Main	DC	Main Voltage possible	
PLC no. of DI	-	PLC no. of DO	2
PLC no. of DIO	-		
PLC no. of AIN	1	Analogue voltage	-/+10VDC, -/+10bit
Multifunction IOs	1		
MTBF 30% [Year]	-	MTBF 100% [Year]	-
Internal Power-Dump Resistance [Ohm]		Internal Power-Dump Power [W]	
PD connection - Int/Ext	None		
External Power-Dump Resistance Minimum value [Ohm]		External Power-Dump Max Current [A]	
Inrush current -Main max [A]		Inrush special	No
Recommended fuse	T10A	P- isolated from Earth (Low Voltage ground (P-) isolated from housing)	No
Resistance [Ohm]		Induction [mH]	
Analogue Output [V]		Analogue Output [mA]	
Analogue Isolated Output Voltage [V]			



JVL A/S | Bregnerødvej 127 | DK-3460 Birkerød | Denmark | Tel. (+45) 4582 4440 | www.jvl.dk | sales@jvl.dk

MAC141-A1AAAA-A009

Int.Servo.AC 134WS1 0.48Nm IP42 Inc G2 conn.

Communication information

Software MacTalk

**Connectivity:
Without module** RS232 - 5VDC, Modbus RTU **e-PLC Files**

**Connectivity:
1 modules** Gen. Yes



MAC141-A1AAAA-A009

Int.Servo.AC 134WS1 0.48Nm IP42 Inc G2 conn.

Cable information

Item number	Mount on	Cable con 1 +Con 1 angle	Cable application	Wires no totally	Cable length [m]
Item description		Cable con 2 +Con 2 angle	Cable flexibility	Wire [mm2]	Connector 1 LED
WI1000-M12F5V05R	Connector PDO	M12 5-pin female A-coded - 90° Angled	Power/Motor/com		5
M12 Shl Cable 5m 5 pin Fem 90°, Power, 3D		- n/a			No
WI1000-M12M8T20R	Connector PDO	M12 8-pin male A-coded - 180° Straight	Power/Motor/com		20
M12 Shl Cable 20m 8 p Male 0° 2D cable chain		- n/a			No
WI1010-M08M4T1.5P	Connector PDO	M8 4-pin male A-coded - 180° Straight	STO		1.5
M8 STO 4Pin Male 0° Con Shl Yel 1.5 m 1xcon, PA014		- n/a	Standard		No

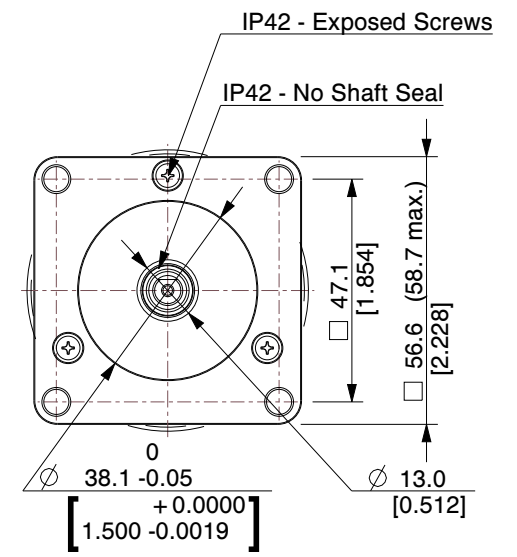
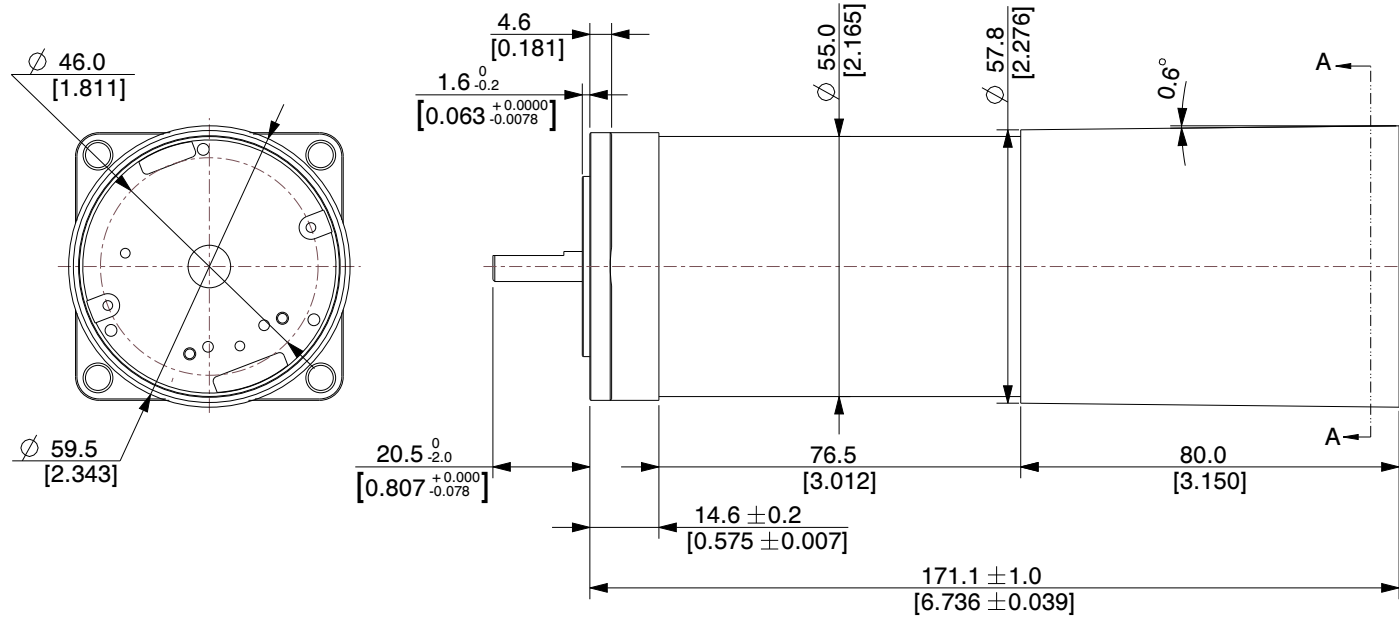
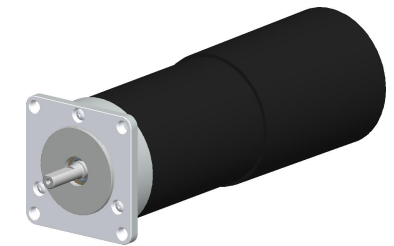
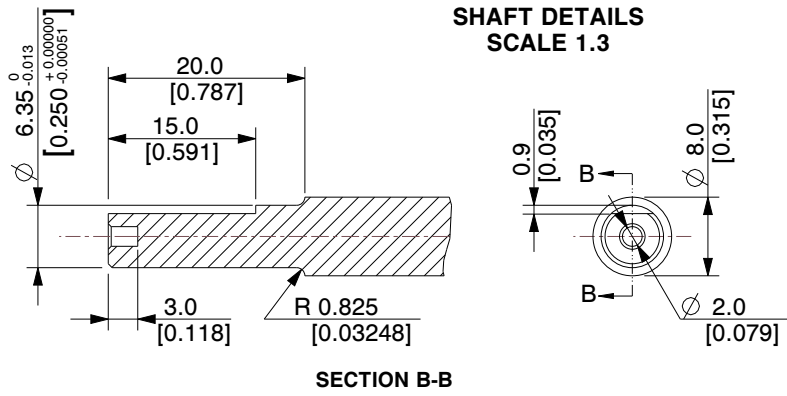
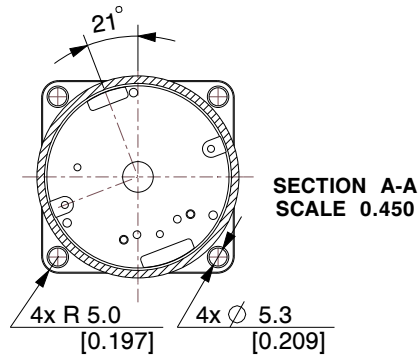

NOTES:
1. Encoder Type: Encoder 4096 CPR

MOTOR SPECIFICATIONS

Rated Torque	0.48 Nm	Supply Voltage	12-48 VDC	Standards	CE approved / UL Pending	Motor Color	Black
Peak Torque	1.59 Nm	Control circuit voltage	-	Maximum angular acceleration	85300rad/sec ²	Usage / Storage Temperature	Ambient 0 to +40°C (32-104°F)
Rated Power (watt)	134 W	Electric time constant (motor)	-	Inertia	0.227 kgcm ²	Housing & Flange	Square flange
Rated power rate. (motor)	-	Peak supply current (worst case)	16A peak	Max. axial shaft load	15N	Protection	IP42 without brake
Speed Range (nominal)	0-2700 RPM	Weight	1.32 kg	Max. radial shaft load	75 N (20mm from flange)	Special Configuration	2. Gen. Connector for Ethernet modules

JVL A/S
Bregnerødvej 127
DK-3460 Birkerød
Denmark

PART NUMBER:
MAC141-A1AAAA-A009

PART DESCRIPTION:
Integrated Stepper Motor

		A4	SCALE	NTS
			UNIT	MM [Inch]

Unless specifically stated otherwise, this drawing is the property of JVL A/S and no feature embodied herein may be disclosed except as previously authorized