



MAC1200-D2-FAAJ

Int.ServoAC 1182WS1 3.82Nm IP55 Abs

MAC motor® is a series of integrated (all-in-one) servo motors with shaft power from 46 W to 4500 W. +400 W and new F-series (50..140 W) are programmable through ePLC (embedded-PLC). Choose between a large number of control modules.

Options include:

- Absolute Multiturn Encoder (incremental encoder is standard)
- Built-in Brake or Brake module (MABxx)
- Ethernet module w/built-in Switch for easy daisy-chaining and all protocols (Profinet, EtherNet/IP, EtherCAT, SERCOS, ModbusTCP/UDP, Powerlink)
- Wireless modules are also available: WLAN or BlueTooth
- CANopen, Devicenet or Profibus or ePLC modules
- Serial communication modules, RS232 and/or RS485
- High IP versions are also available (IP 65..66..67)
- Food or Medico types in Stainless Steel IP69K

Unique Ethernet functionality: use MacTalk® (PC software) to change freely between all the different Ethernet protocols, you don't need several different types on stock – ONE is enough.



General information

Description	Int.ServoAC 1182WS1 3.82Nm IP55 Abs , WxHxL: 80x120x203 mm. 3000 RPM. 3.82 Nm RMS / 11.46 Nm Peak Single phase 230VAC input. Notice this motor is not UL Approved No isolation P-/Earth (standard), IP55, Single 8192 CPR / Absolute multiturn ±8178 revs, Color: Black, Ø19x40 mm with keyway 6x30 mm		
Manufacture	JVL	Motor type	Integr. AC-servo - Rotating
Motor power [W]	1182	Power Peak [W]	3546
Duty Cycle	S1	Max Duty Cycle [%]	100
Continuous Torque	3.82	Peak torque [Nm]	11.46
Main supply [V]	115, 230	Voltage type - Main	AC
Speed [Rpm]	3000	Connectivity: Without module	RS232 - 5VDC, Modbus RTU
Encoder type	Abs. Multiturn Encoder +/- 8178 rev.	Encoder [Counts/rev]	8192
Integrated PLC	Yes	Brake	No
STO connector	No	Fan mounted	Yes
Integrated gear	No	Gear ratio	-
Approval - UL	No	Approval TÜV - STO	No
PLC no. of AIN	2	PLC no. of DI	-



MAC1200-D2-FAAJ

Int.ServoAC 1182WS1 3.82Nm IP55 Abs

General information

PLC no. of DIO	-	PLC no. of DO	2
Multifunction IOs	2		
Flange size	80x80	Protection house	IP55
Shaft size - Front [mm]	19.00mm	Protection shaft	IP55
Color	Black	Paint type	
Ambient Temperature range:		Max. Amb. Temperature range - Torque derating:	
Maximum Installation Altitude:		Max. Installation Altitude - Power Derating every 1000m:	
Weight net [kg]	4.00	Weight gross [kg]	4.51
Tariff no	85015100	Country Of Origin	DK



MAC1200-D2-FAAJ

Int.ServoAC 1182WS1 3.82Nm IP55 Abs

Mechanical information

Motor type	Integr. AC-servo - Rotating	Color	Black
Rotor inertia [kgcm²]	1.600	Max inertia factor	20
Encoder type	Abs. Multiturn Encoder +/- 8178 rev.	Encoder [Counts/rev]	8192
Precision Motor - Absolute [Deg -/+]	0.04	Precision Motor - Max Load [Deg -/+]	
Precision Motor - Repeatability [Deg -/+]	0.04		
Brake	No	Brake - Go ON time [ms]	-
Brake Holding torque [Nm]	-	Brake - Go OFF time [ms]	-
Radial load [N]	xxx	Radial load distance [mm]	
Axial load [N]	xxx		
Axial play [mm]	xxx	Axial play force [N]	xxx
Front bearing type	xxx	Rear bearing type	xxx
Integrated gear	No	Gear ratio	-
Gear efficiency [%]	-	Gear backlash [ArcMin]	-
Motor length [mm]	203.0	Motor width [mm]	84.0
Motor height [mm]	120.0	Protection house	IP55
Customer Sealing	Standard		
Flange size	80x80	Mounting holes front [mm]	5.5
Motor diameter center front [mm]	70.0	Bolt circle diameter front [mm]	90.0
Flange material		Flange Thickness [mm]	
Shaft Key included	Key included on shaft	Shaft Key Dimension	6x6x30
Shaft size - Front [mm]	19.00mm	Protection shaft	IP55
Shaft length Front [mm]	40.0	Shaft material	Steel
Approval - ROHS-3	Yes	Approval - UL	No
Approval TÜV - STO	No	Approval - ATEX	No
CAD 2D [PDF]	Download	CAD 3D [STEP]	Download
CAD 2D [DWG]	No	CAD 3D [DWG]	No



MAC1200-D2-FAAJ

Int.ServoAC 1182WS1 3.82Nm IP55 Abs

Mechanical information

CAD 3D [EASM]	No	CAD 3D [IGES]	No
Datasheet - pdf	Download	User Manual	Download
REACH SVHC document	Download	Low voltage Directive	EU Declarations of Conformity
No Dual Use	-		

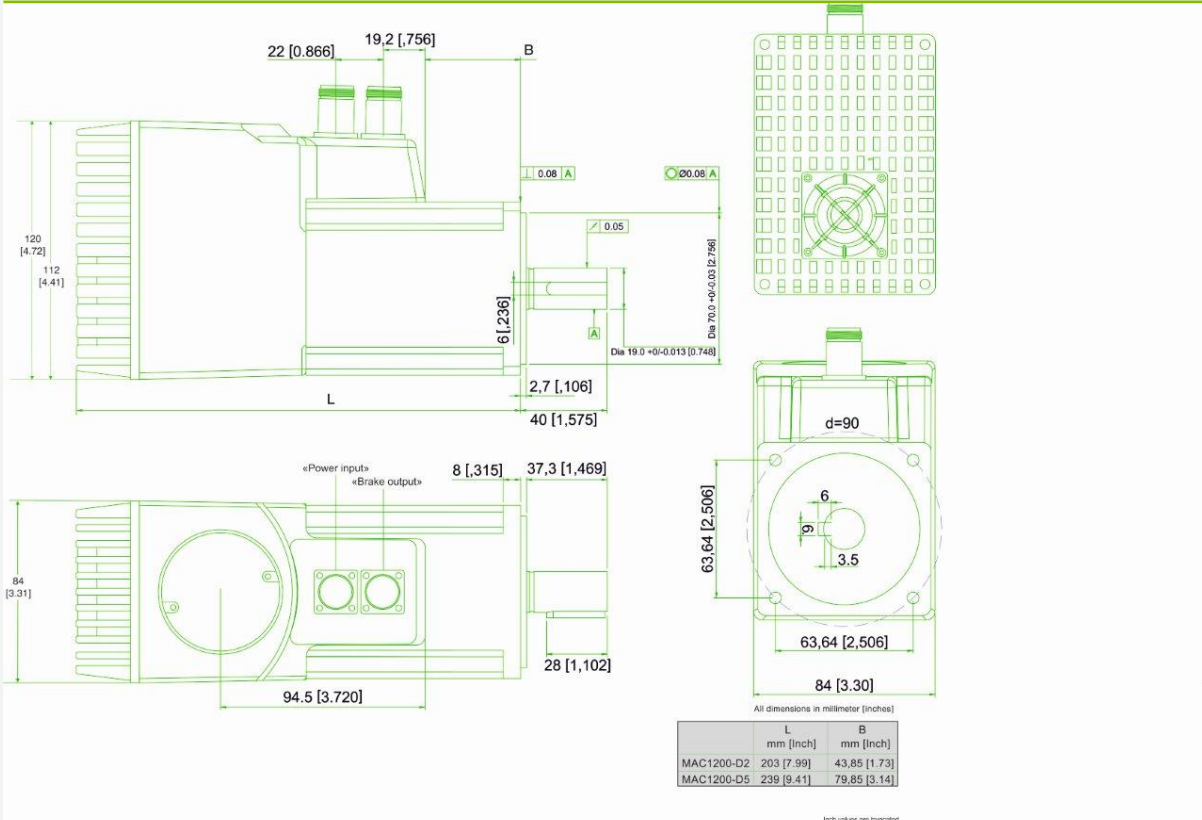

Shaft Seal



MAC1200-D2-FAAJ

Int.ServoAC 1182WS1 3.82Nm IP55 Abs

Connector information

Motor connectors

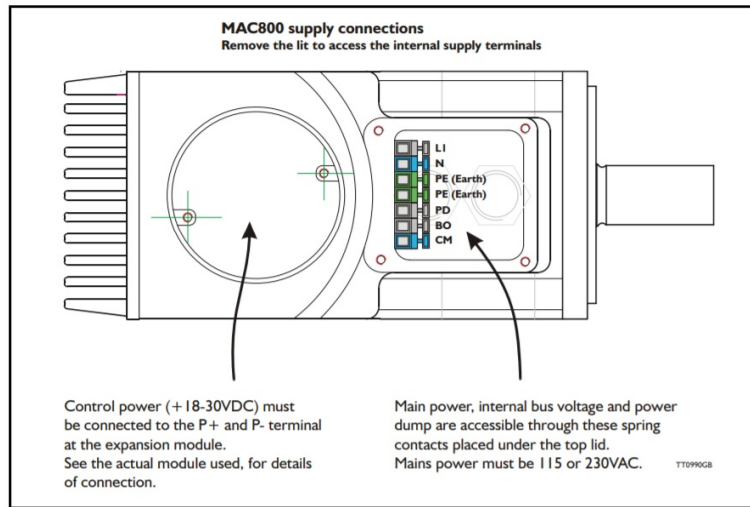

Expansion connector	Generation 1 and 2		
PLC no. of DI	-	PLC no. of DO	2
PLC no. of DIO	-	PLC no. of AIN	2
Multifunction IOs	2		
Connector Power	PG12 - Internal terminal	Connector Power Supplier	
Connector Power direction	Straight		
Connector PDO	PG12 - Internal terminal	Connector PDO Supplier	
Connector STO	No		
Module connections	Here - Click for module cable connections		



MAC1200-D2-FAAJ

Int.ServoAC 1182WS1 3.82Nm IP55 Abs

Torque, force and Power information

RMS torque [Nm]	3.82	Peak torque [Nm]	11.46
Supply Volt 1 [V]	1x115	Supply Volt 2 [V]	1x230
Supply Volt 3 [V]		Supply Volt 4 [V]	-

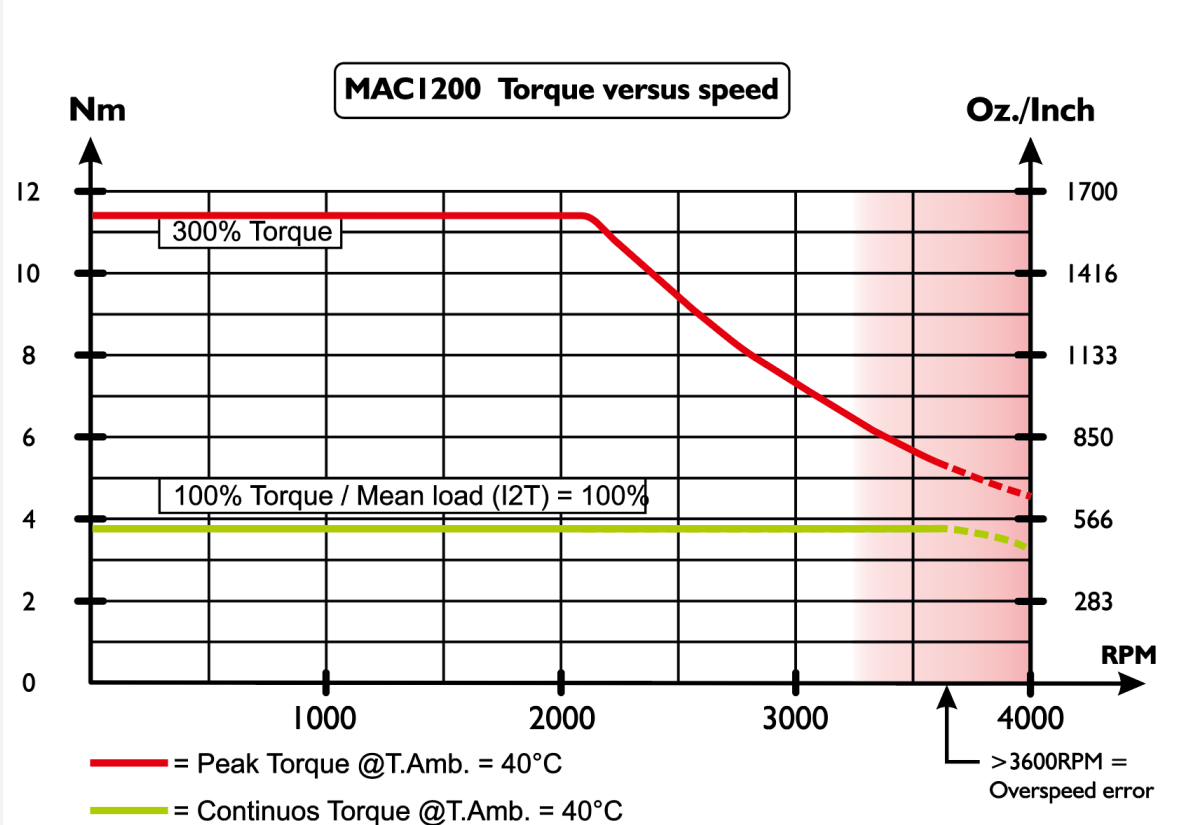



MAC1200-D2-FAAJ

Int.ServoAC 1182WS1 3.82Nm IP55 Abs

Electrical information

Control voltage (CVI/O+) [VDC]	18-28	Control Voltage (CVI) Min-Max [VDC]	18-30
Main supply [V]	115, 230	Main supply Min-Max [V]	90-260
Voltage type - Main	AC	Main Voltage possible	1x115VAC, 1x230VAC
PLC no. of DI	-	PLC no. of DO	2
PLC no. of DIO	-		
PLC no. of AIN	2	Analogue voltage	-/+10VDC, -/+11bit
Multifunction IOs	2		
MTBF 30% [Year]	-	MTBF 100% [Year]	-
Internal Power-Dump Resistance [Ohm]	68	Internal Power-Dump Power [W]	9
PD connection - Int/Ext	Int/Ext PD in Parallel		
External Power-Dump Resistance Minimum value [Ohm]	33	External Power-Dump Max Current [A]	100
Inrush current -Main max [A]		Inrush special	Yes
Recommended fuse	115VAC: FRN-R-15 Cooper Bussmann inc. 230VAC: T10A@230VAC type gG, Do or Dz.	P- isolated from Earth (Low Voltage ground (P-) isolated from housing)	No
Resistance [Ohm]		Induction [mH]	
Analogue Output [V]		Analogue Output [mA]	
Analogue Isolated Output Voltage [V]			



MAC1200-D2-FAAJ

Int.ServoAC 1182WS1 3.82Nm IP55 Abs

Communication information

Software MacTalk

Connectivity: RS232 - 5VDC, Modbus RTU **e-PLC Files**

Without module

Connectivity: **Gen.** Yes

1 modules

Connectivity: **Gen.** Yes

2 modules



JVL A/S | Bregnerødvej 127 | DK-3460 Birkerød | Denmark | Tel. (+45) 4582 4440 | www.jvl.dk | sales@jvl.dk

MAC1200-D2-FAAJ

Int.ServoAC 1182WS1 3.82Nm IP55 Abs

Cable information

Item number	Mount on	Cable con 1 +Con 1 angle	Cable application	Wires no totally	Cable length [m]
Item description		Cable con 2 +Con 2 angle	Cable flexibilit	Wire [mm2]	Connector 1 LED

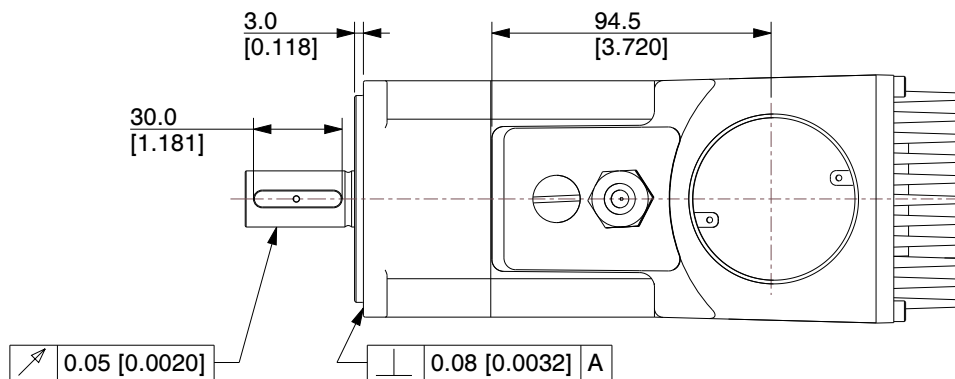
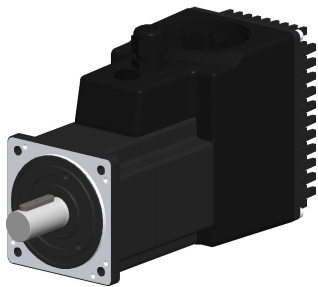
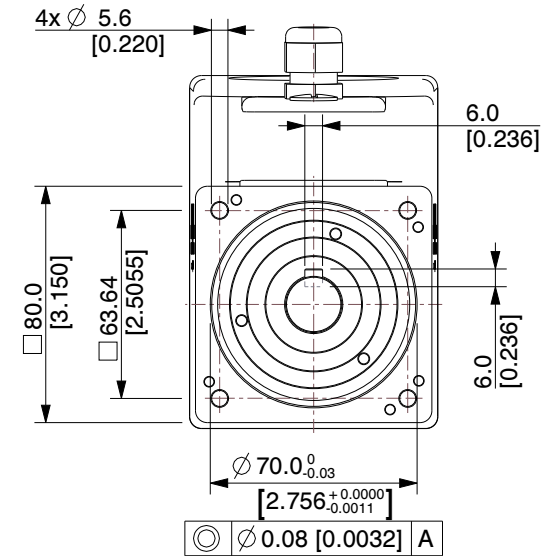
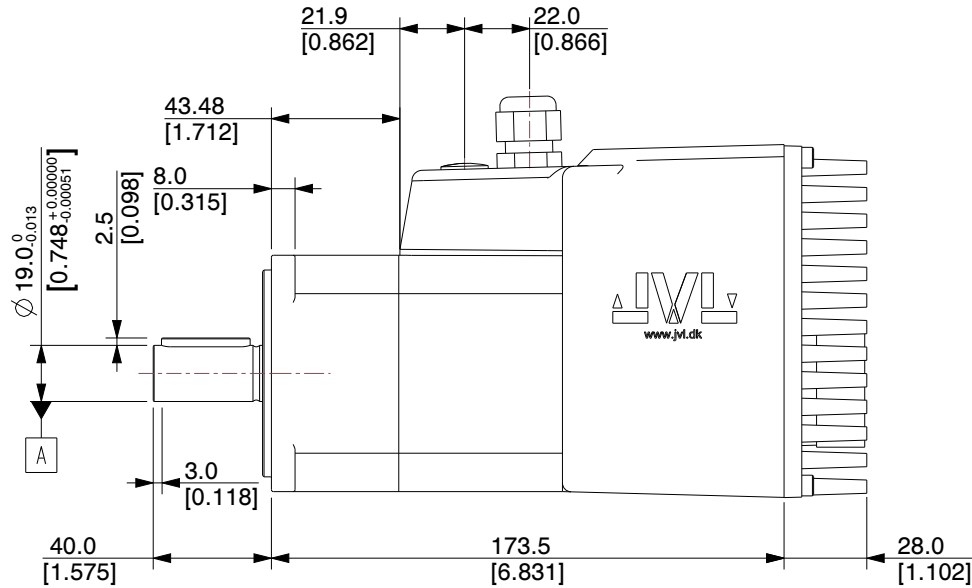
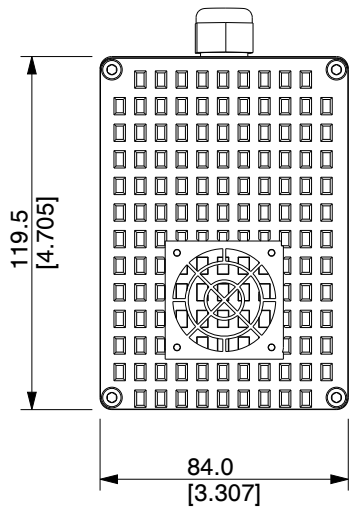



NOTES:
1. Encoder Type: Absolute multiturn 4096 Rev. Single 8192 CPR

MOTOR SPECIFICATIONS



Running Torque	3.82 Nm	Supply Voltage	115/230VAC (± 10%), 47-63Hz	Standards	CE approved / UL File: E254947	Motor Color	Black
Peak Torque	11.46 Nm	Control circuit voltage	18-32VDC	Acceleration range	250 - 444.675 RPM/sec	Operating Temperature	Ambient 0 to +40°C (32-104°F)
Rated Power (watt)	1182 W	Electrical time constant (motor)	4.122 ± 10% ms	Inertia	1.6 kgcm ²	Housing & Flange	Square Flange
Rated power rate. (motor)	62.8 kW/s	Mechanical time constant (motor)	0.428 ± 10% ms	Max. axial shaft force	11kg	Protection	IP55
Speed (range)	0-3000RPM	Weight	5.02 kg	Max. radial shaft force	18kg (20mm from flange)	Special Configuration	-

JVL A/S
Bregnerødvej 127
DK-3460 Birkerød
Denmark

PART NUMBER:
MAC1200-D2-FAAJ

PART DESCRIPTION:
Integrated Stepper Motor

  A4	SCALE	NTS
	UNIT	MM [Inch]

Unless specifically stated otherwise, this drawing is the property of JVL A/S and no feature embodied herein may be disclosed except as previously authorized